



## BSM WELLHEAD

The Split Compact Wellhead incorporates casing head spools and tubing head spool in a body that can be easily split if necessary.

### BSM MAIN FEATURES:

- Rig time to nipple up BOPs is eliminated, thus shortening the operation time compared to the conventional wellhead system.
- Casing hangers are self-centralizing.
- Snap rings prevent any individual string movement due to thermal growth or expansion.
- Inventory overheads are lowered by reduction of required components.
- H2S service is standard on wellhead bodies.
- Casings are suspended and cut as per conventional wellhead system in case of contingency. No internal casing cutter is needed.
- Quick Lock Connectors allow a drastically reduction of the operation time.

**Sizes: 13.5/8" through 21.1/4"**

**Working Pressure up to 69 MPa (10000 psi)**

**Temperature range -29°C ÷ 121°C (-20°F ÷ 250°F)**

**Top connection: Quick Lock "SL" or Flanged Hub**

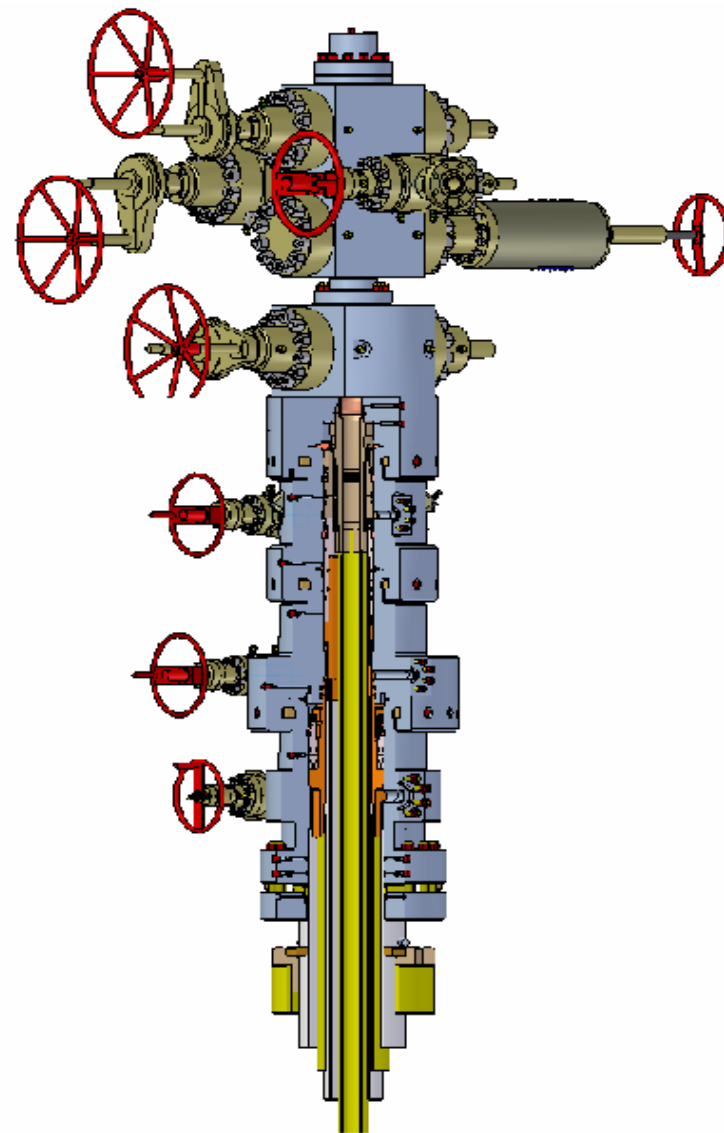



## BSM WELLHEAD

The Split Compact Wellhead incorporates casing head spools and tubing head spool in a body that can be easily split if necessary.

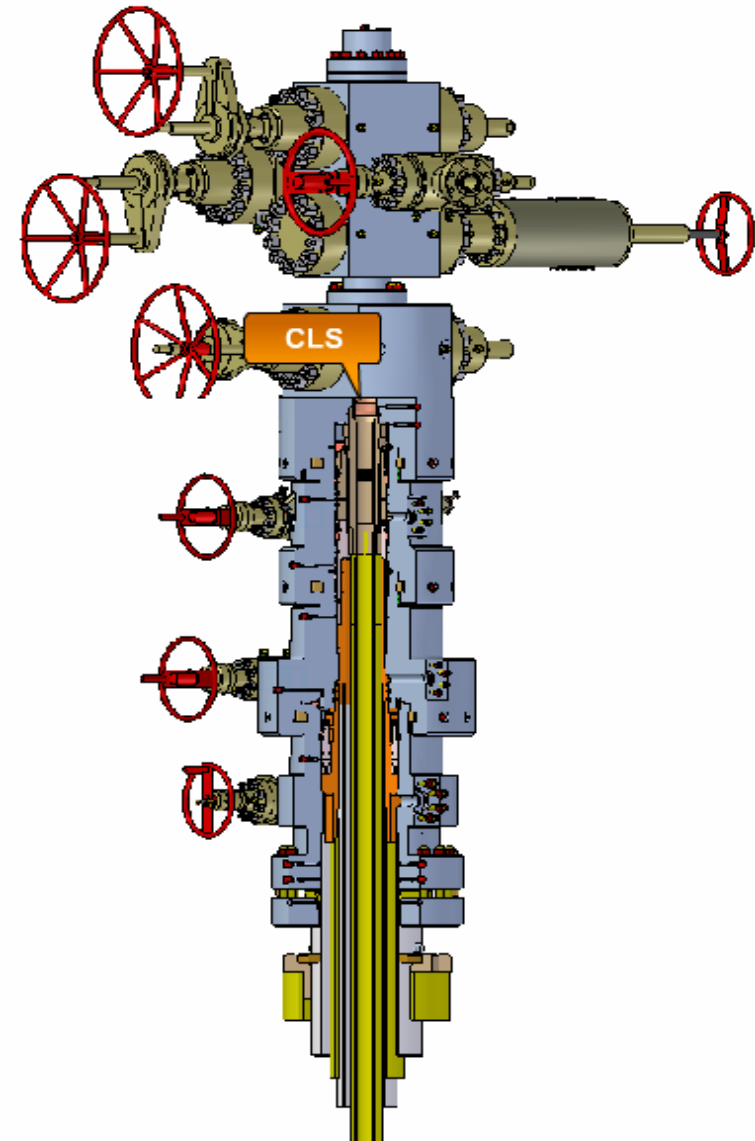
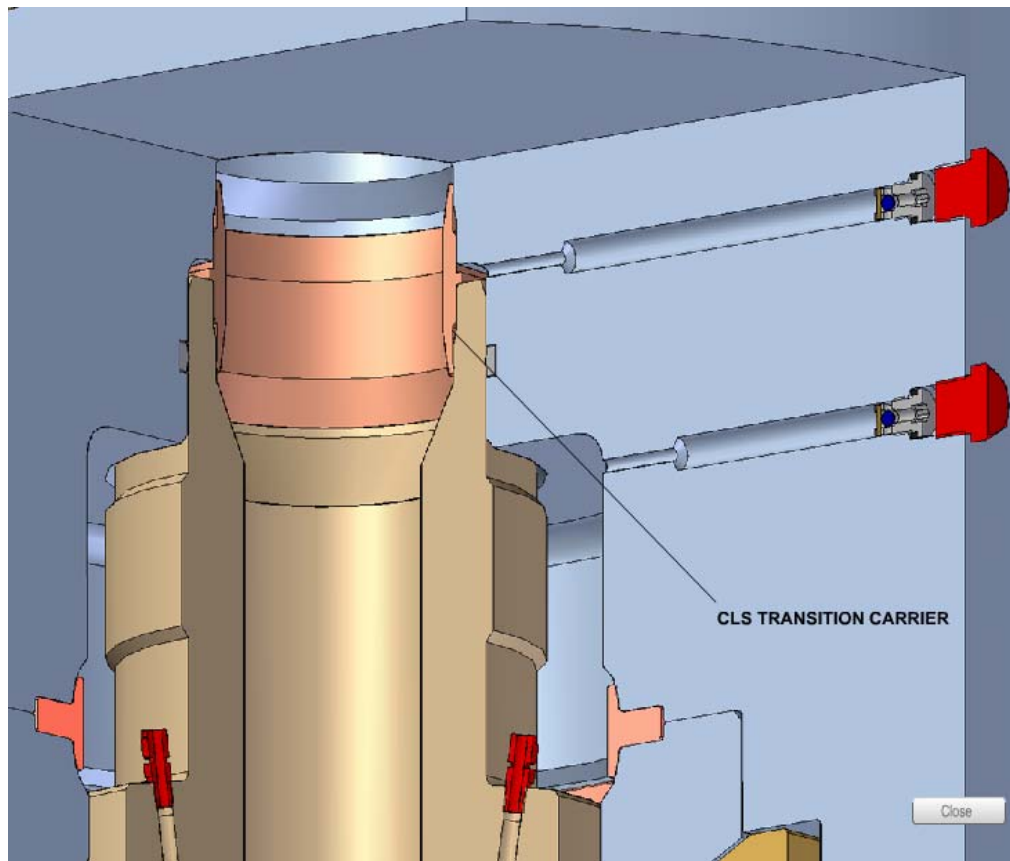



## BSM WELLHEAD

The Split Compact Wellhead incorporates casing head spools and tubing head spool in a body that can be easily split if necessary.

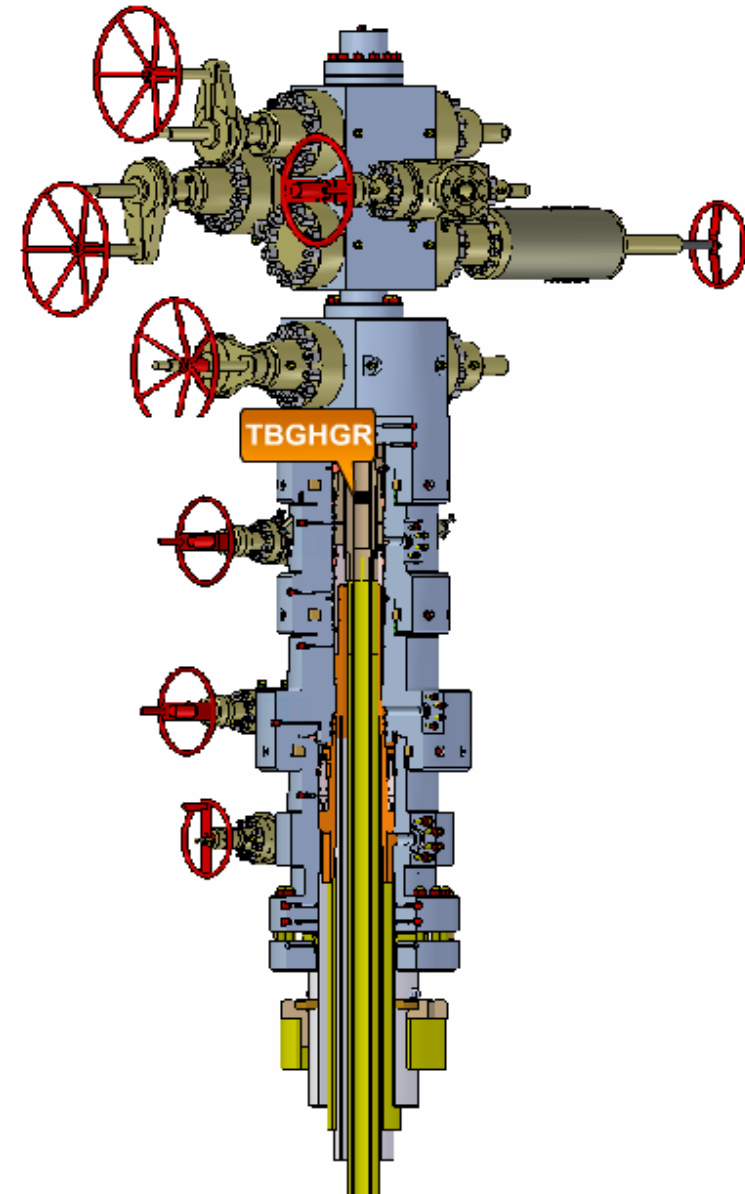
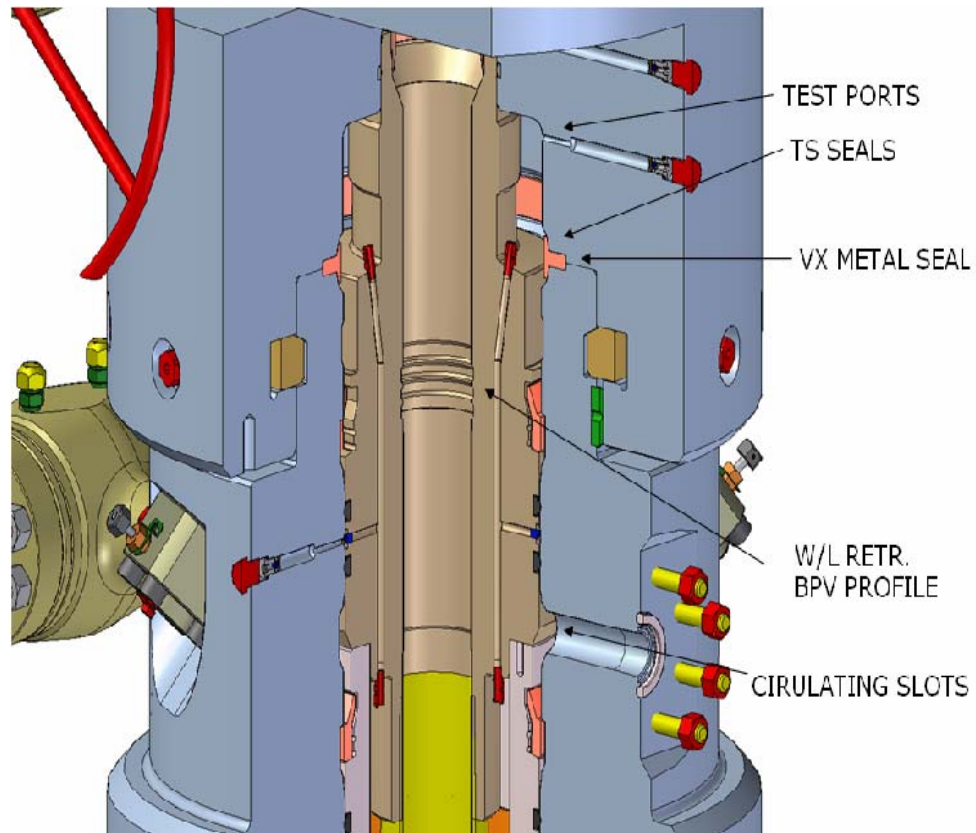



## BSM WELLHEAD

The Split Compact Wellhead incorporates casing head spools and tubing head spool in a body that can be easily split if necessary.

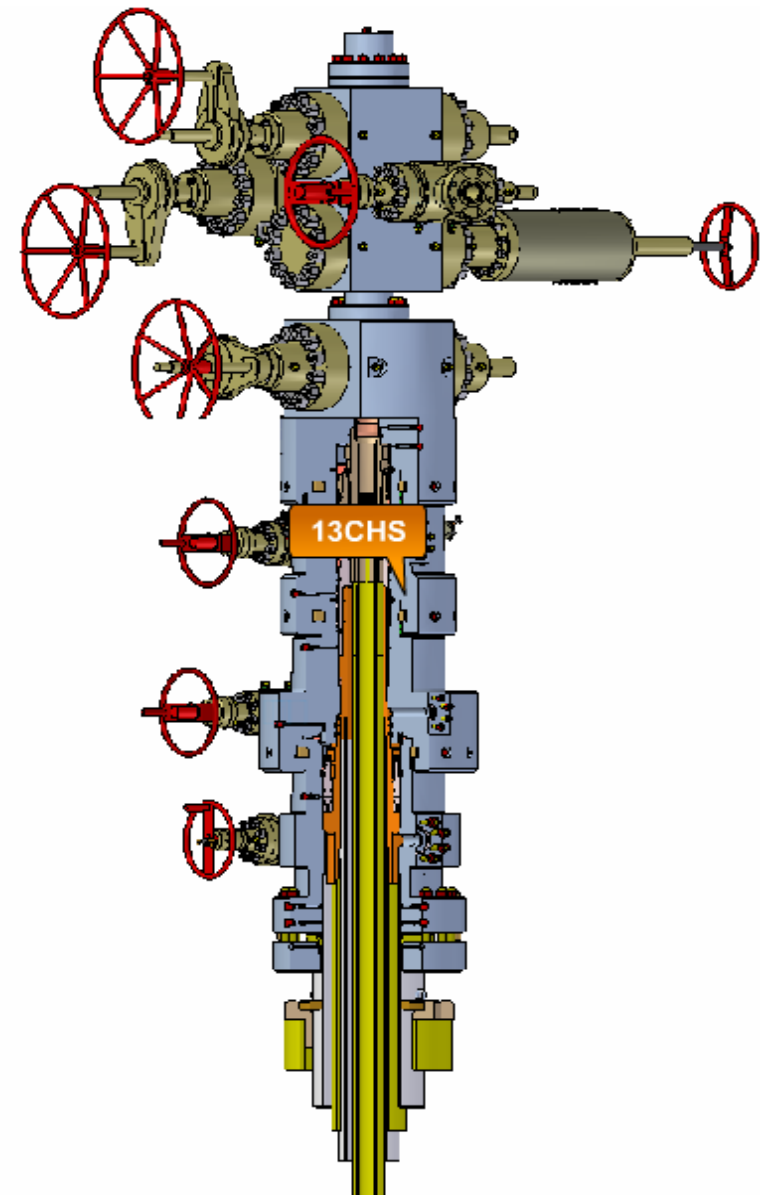
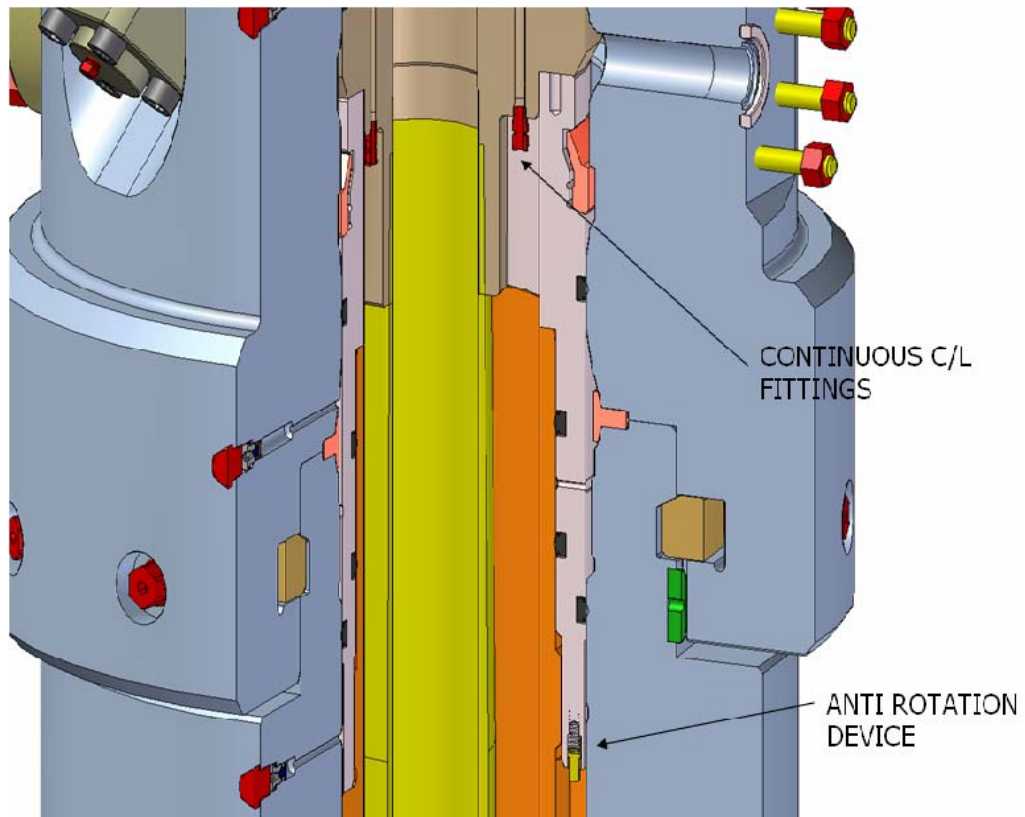



## BSM WELLHEAD

The Split Compact Wellhead incorporates casing head spools and tubing head spool in a body that can be easily split if necessary.

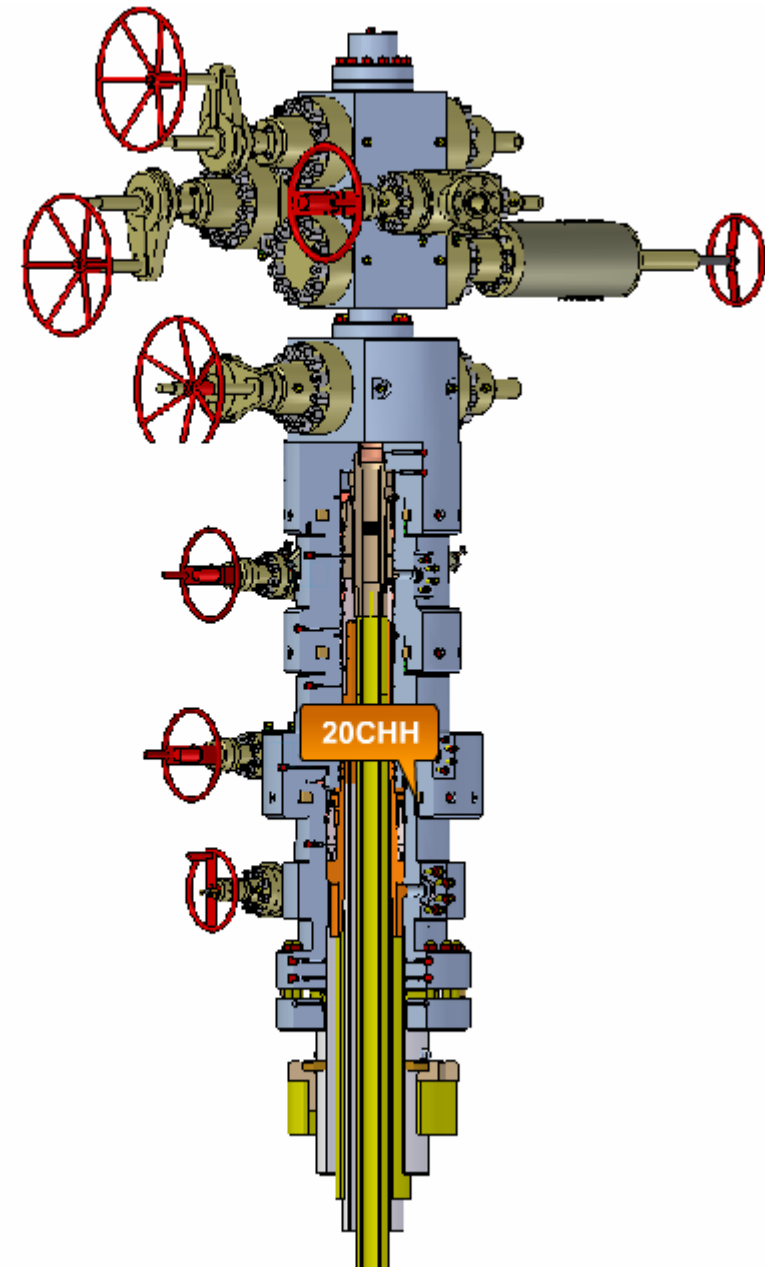
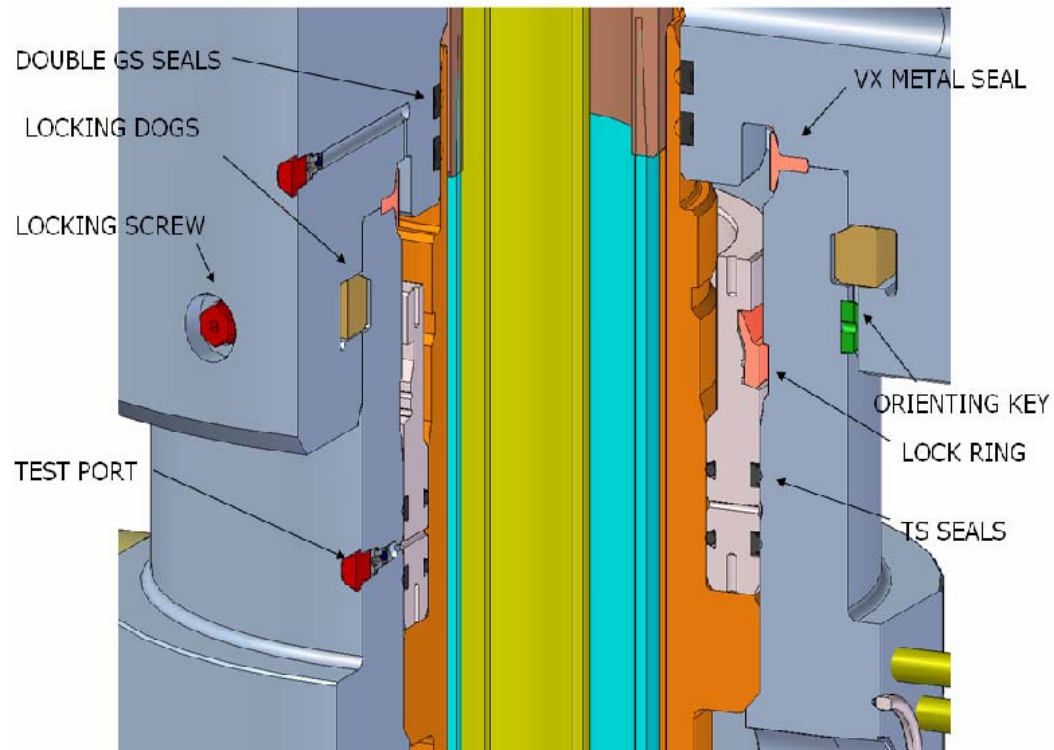



## BSM WELLHEAD

The Split Compact Wellhead incorporates casing head spools and tubing head spool in a body that can be easily split if necessary.

